

Dual Check Isolation Valve, BVQ25-20-2NV

FEATURES

- 20mm (3/4") PRESS fit Water Fitting
- Double check & isolation combination
- Stainless steel handle
- Body DR Brass
- Isolating Disc & 1" hex nipple
- Complies with AS2845

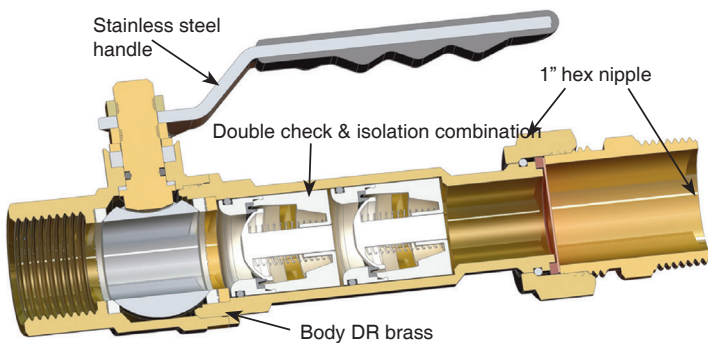
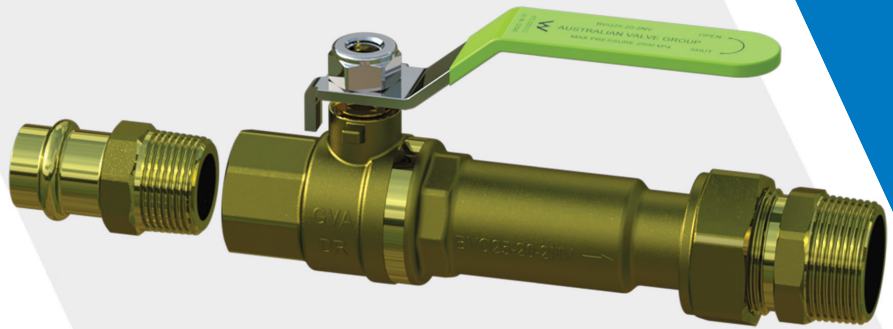

BVQ25-20-2NV DIMENSIONS

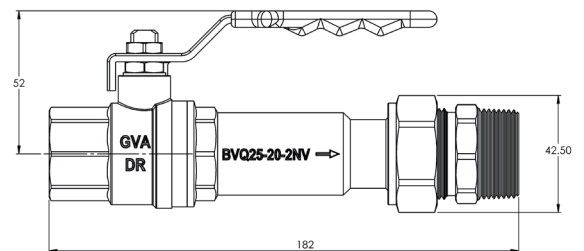

PRESSURE COMPARISON

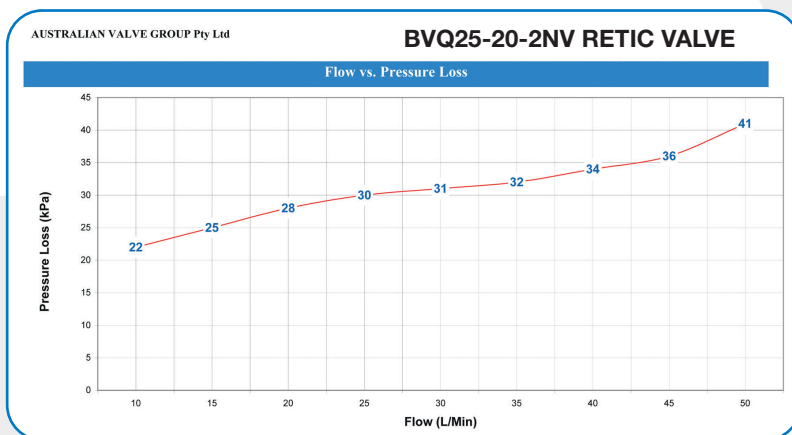

TYPICAL INSTALLATION

Model BVQ25-20-2NV Dual Check Isolation Valve should be installed with adequate clearance and easy accessibility for testing and maintenance and must be protected from freezing. Local codes shall govern installation requirements.

Fittings such as end connectors intended to join alternative pipe systems made from other materials (e.g. plastics) shall also conform to the relevant dimensional and performance requirements of the appropriate Australian, New Zealand, or joint Australian/New Zealand Standard for the alternative pipe system.

Test the assembly at initial installation, after servicing or maintenance to AS/NZS2845.3 and local regulatory authority requirements.

DISCLAIMER: Every care has been taken in the preparation of these instructions, which have been issued as a guide only. Compliance with the requirements of local Authorities is required at all times. These requirements may change from time to time. Always be aware of the local requirements. Subject to any statutory obligations and manufacturers warranties no liability can be accepted for any losses, consequential or otherwise which may arise or be said to have arisen from relying upon the contents of this installation instruction as to the fitness of any particular product for any particular purpose, use or application. The Australian Valve Group Pty Ltd reserves the right to modify designs and specifications and to withdraw and introduce products at any time without notice.